



A.D. PRODUZIONE SRL

+39 02 33 50 24 97

info@adproduzione.it

www.adproduzione.com

A.D. Produzione s.r.l.

TYRE INFLATOR - mod. GGIP080 - GGIP0160

Unite of measure: cm

EXAMPLE OF MASONRY WORKS

FOR TECHNICAL DETAILS ASK TO A PROFESSIONAL TECHNICIAN

CAUTION

- Interventions to be checked in accordance with the wall conditions.
- Electrical connections made during installation must ensure the regulations in force.
- Installed power: 500 W (230 V).
- Electrical cables must not be twisted, overlapping and rubbing against sharpe edge.

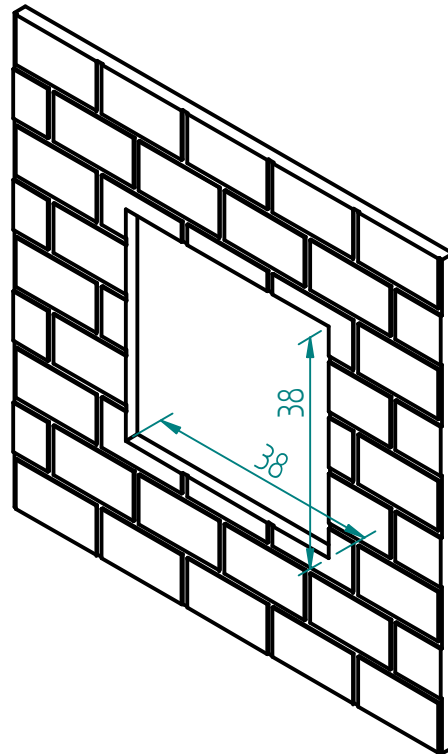
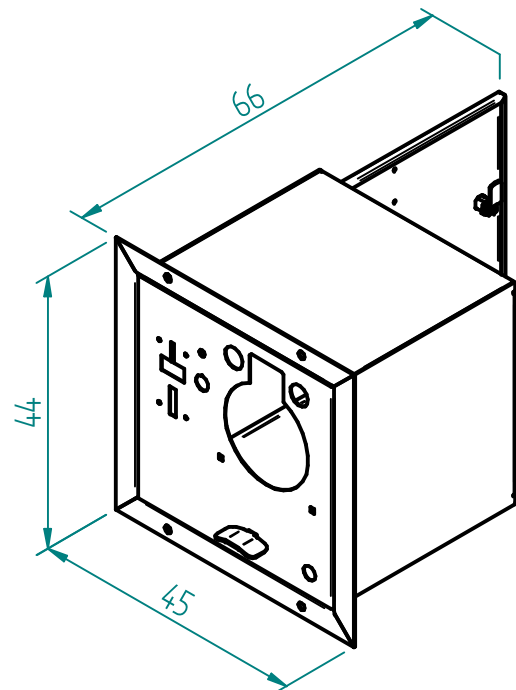

INFERIOR PANEL - **FACE A**

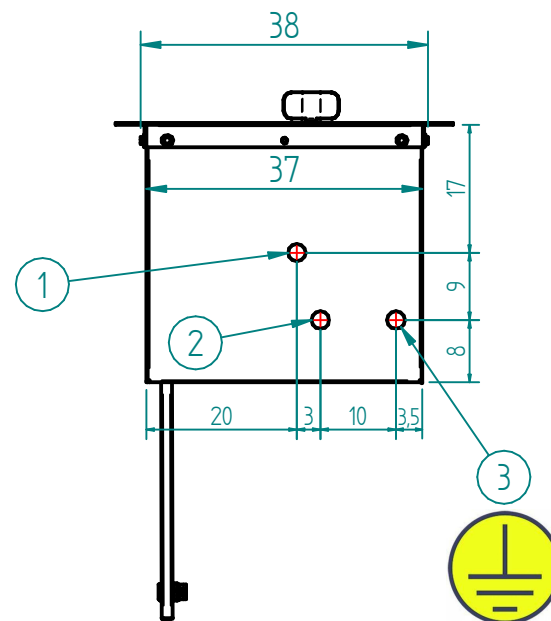

- 1) \varnothing 23 mm hole for the passage of the compressed air hose
- 2) \varnothing 23 mm hole for the passage of the electrical wire P+N+T section 2,5 mm
- 3) \varnothing 23 mm hole for the passage of the grounding obligation wire - Ground connection point of the structure.

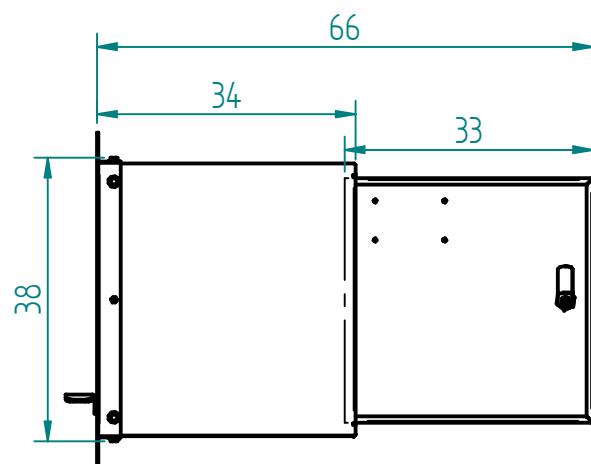

SIDE PANEL - **FACE B**

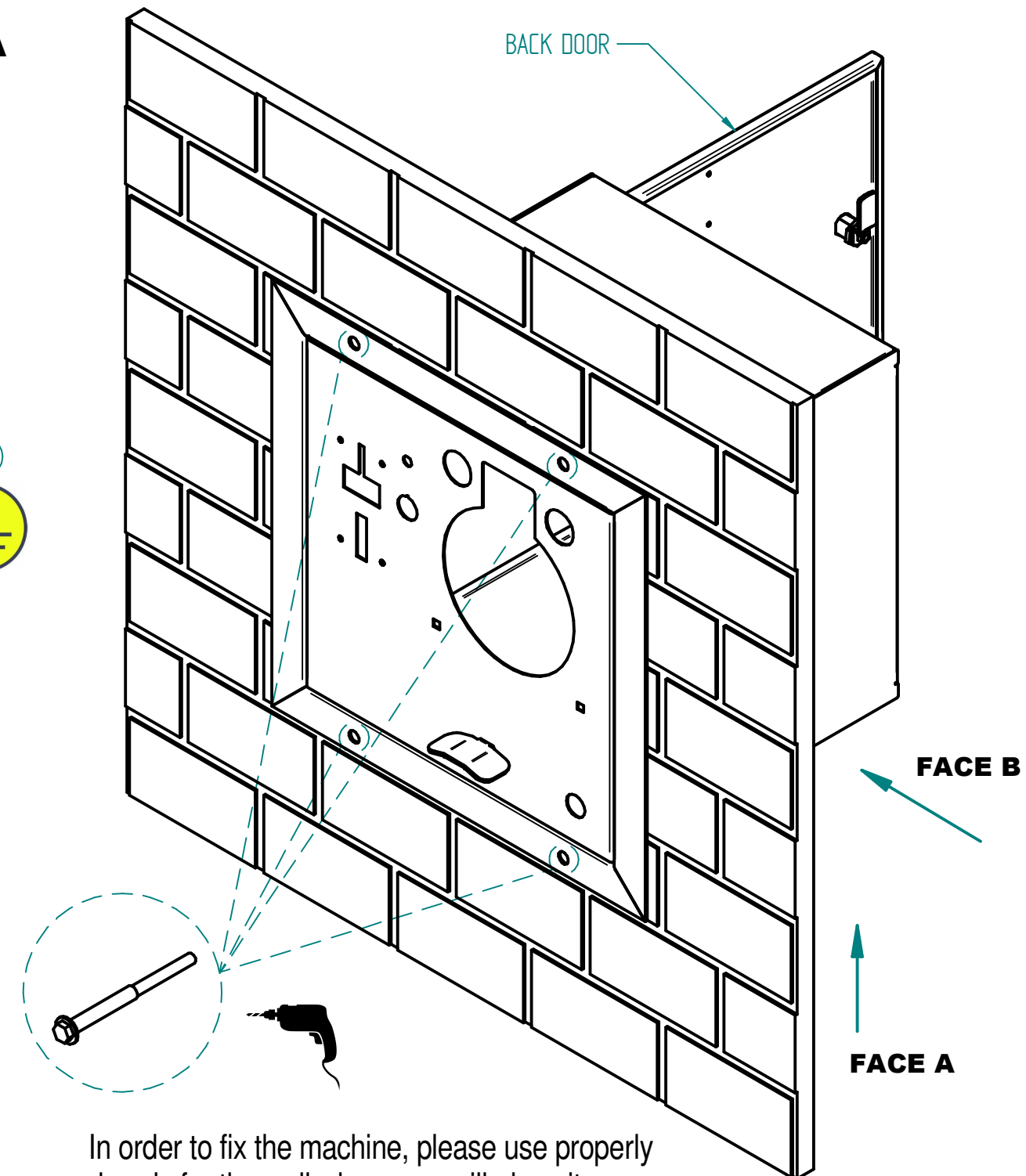
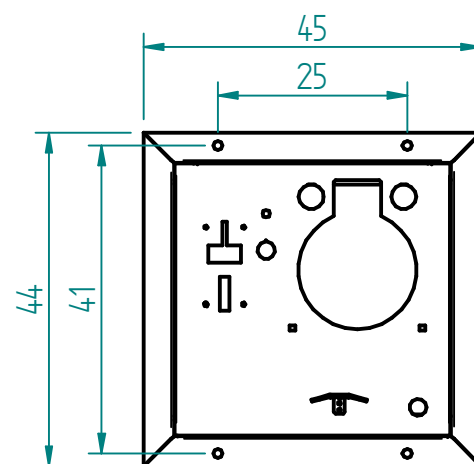

In order to fix the machine, please use properly dowels for the wall where you will place it.