

A.D. PRODUZIONE SRL

+39 02 33 50 24 97

info@adproduzione.it

www.adproduzione.com

A.D. Produzione s.r.l.

DISPENSER PANNOMATIC-N

Unite of measure: cm

EXAMPLE OF MASONRY WORKS

FOR TECHNICAL DETAILS ASK TO A PROFESSIONAL TECHNICIAN

CAUTION

- Interventions to be checked in accordance with geotechnical conditions of soil.
- Electrical connections made during installation must ensure the regulations in force.
- Installed power: 200 W.
- Electrical cables must not be twisted, overlapping and rubbing against sharpe edge.
- All the extremites of the tubes must stick out by 20 cm.

--- MACHINE MAIN DIMENSIONS

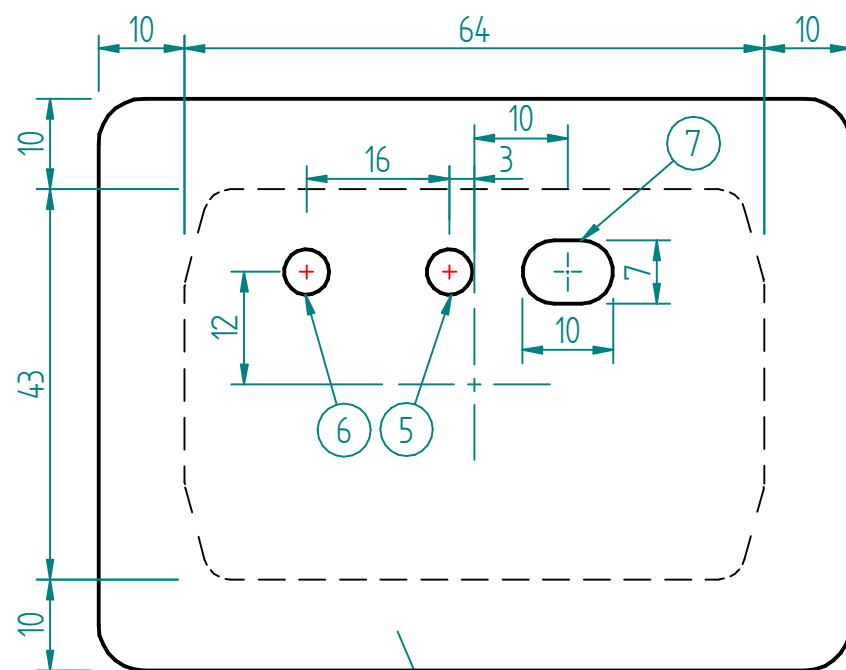

FRONT OF THE MACHINE

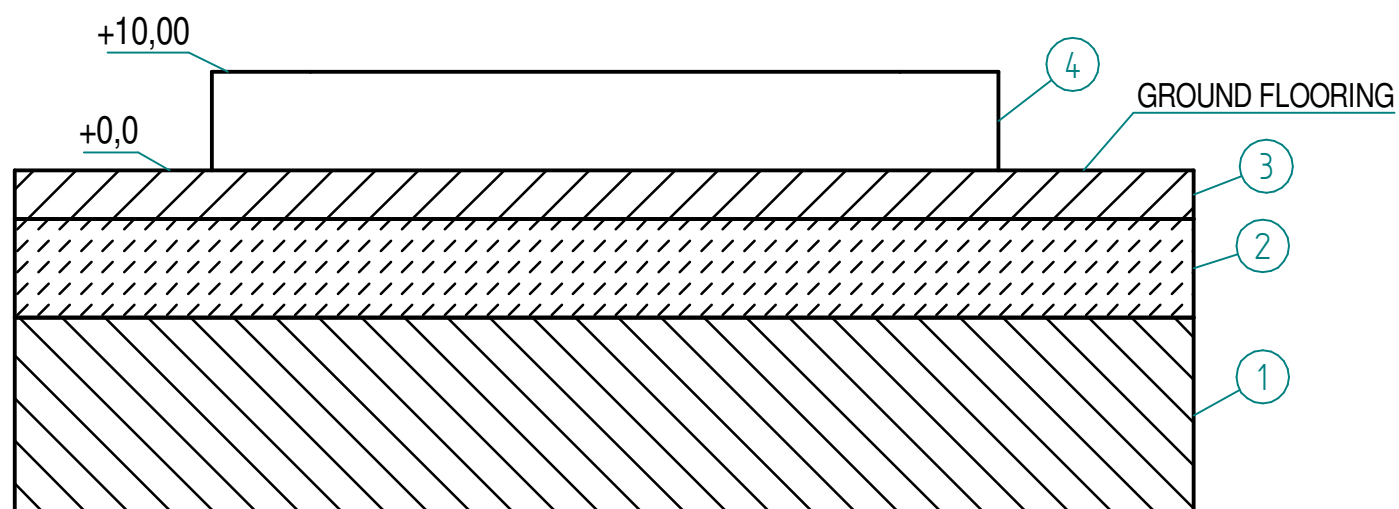

- 1) Washed sand
- 2) Lean concrete with 10 cm thickness with 5 mm diameter welded mesh
- 3) Walkable floor - Flooring as per your forecourt
- 4) cls r' ck 250 kg/cm²
- 5) Grounding obligation - Ground connection point of the structure (the cord must come out by 2 m from the flooring)
- 6) 50 mm diameter p.v.c. hose for passage of the P+N+T type electric cable section 2,5 mm (the cable must come out at least 2 meters out of the flooring to allow the electrical connection)
- 7) Predisposition for eventual centralized vacuum system for tokens

