



A.D. PRODUZIONE SRL

+39 02 33 50 24 97

info@adproduzione.it

www.adproduzione.com

LEATHER SQUEEZER - mod. SPC19 - SPR19

Unite of measure: cm

EXAMPLE OF MASONRY WORKS

FOR TECHNICAL DETAILS ASK TO A PROFESSIONAL TECHNICIAN

- 1) Washed sand
- 2) Lean concrete with 10 cm thickness with 5 mm diameter welded mesh
- 3) Walkable floor - Flooring as per your forecourt
- 4) cls r' ck 250 kg/cm²
- 5) 60 mm diameter water exhaust p.v.c. tube (preparing tube slope to help water drainage)

6) 1/2" tube with gate valve - incoming water with min. pressure 3 bar

If you have the electrical pedal and the antifreeze system as optional:

7) 50 mm diameter p.v.c. hose for the passage of the P+N+T type electric cable section 2,5 mm (the cable must come out at least 1 meter out of the flooring to allow the electrical connection)

8) Grounding obligation - Ground connection point of the structure (the cord must come out by 1 m from the flooring)

CAUTION

- Interventions to be checked in accordance with geotechnical conditions of soil.
- Electrical connections made during installation must ensure the regulations in force.
- Installed power (if you have the electrical pedal and the antifreeze system as optional): 500 W (230 V).
- Electrical cables must not be twisted, overlapping and rubbing against sharpe edge.
- All the extremities of the tubes must stick out by 20 cm.

--- MACHINE MAIN DIMENSIONS

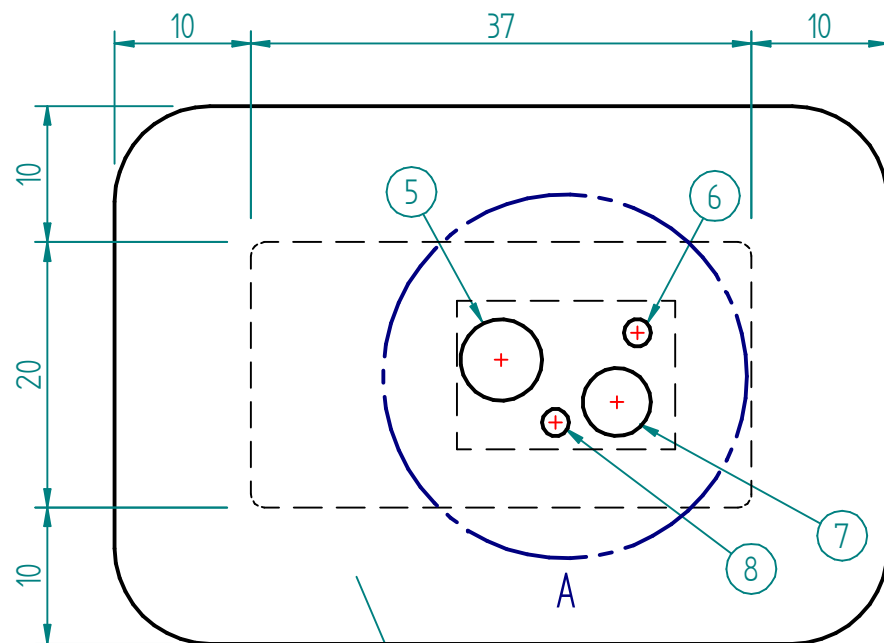

FRONT OF THE MACHINE

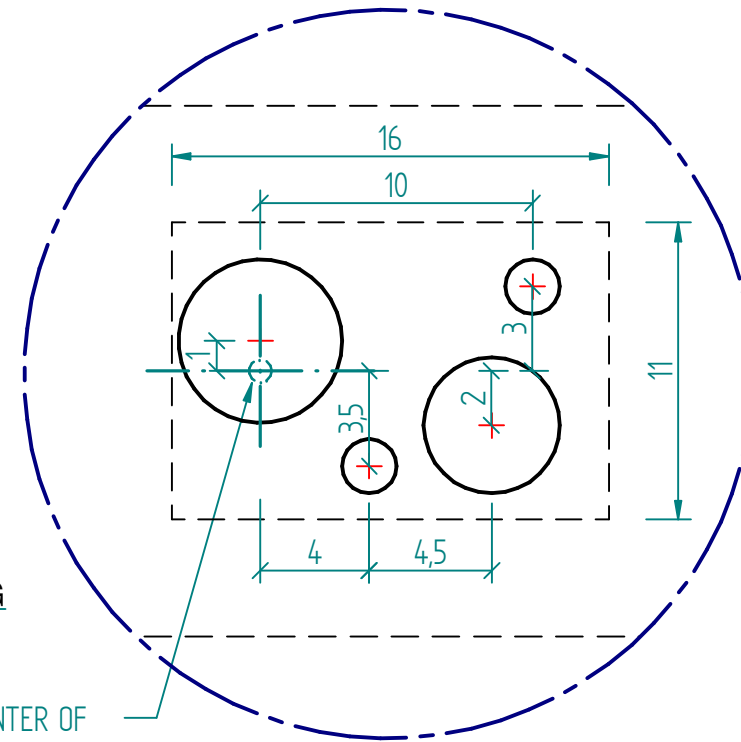

CENTER OF THE MACHINE

DETAIL A

