



A.D. PRODUZIONE SRL

+39 02 33 50 24 97

info@adproduzione.it

www.adproduzione.com

VACUUM CLEANERS mod. AD-00DC and AD-01DC

Unite of measure: cm

EXAMPLE OF MASONRY WORKS

FOR TECHNICAL DETAILS ASK TO A PROFESSIONAL TECHNICIAN

CAUTION

- Interventions to be checked in accordance with geotechnical conditions of soil.
- Electrical connections made during installation must ensure the regulations in force.
- Installed power: AD-00DC = 2 x 2,2kW and AD-01DC = 2 x 3,0kW.
- Electrical cables must not be twisted, overlapping and rubbing against sharpe edge.
- All the extremities of the tubes must stick out by 20 cm.

--- MACHINE MAIN DIMENSIONS

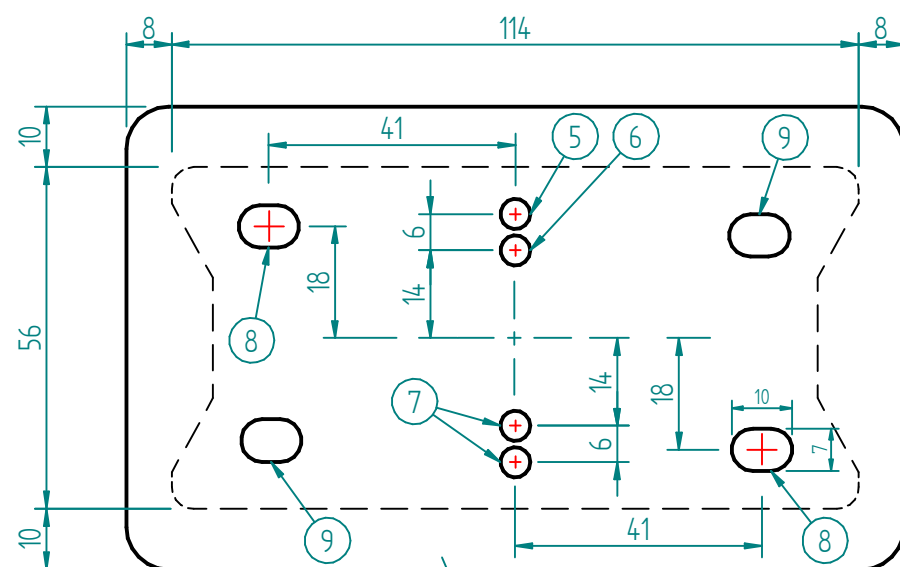

FRONT OF THE MACHINE

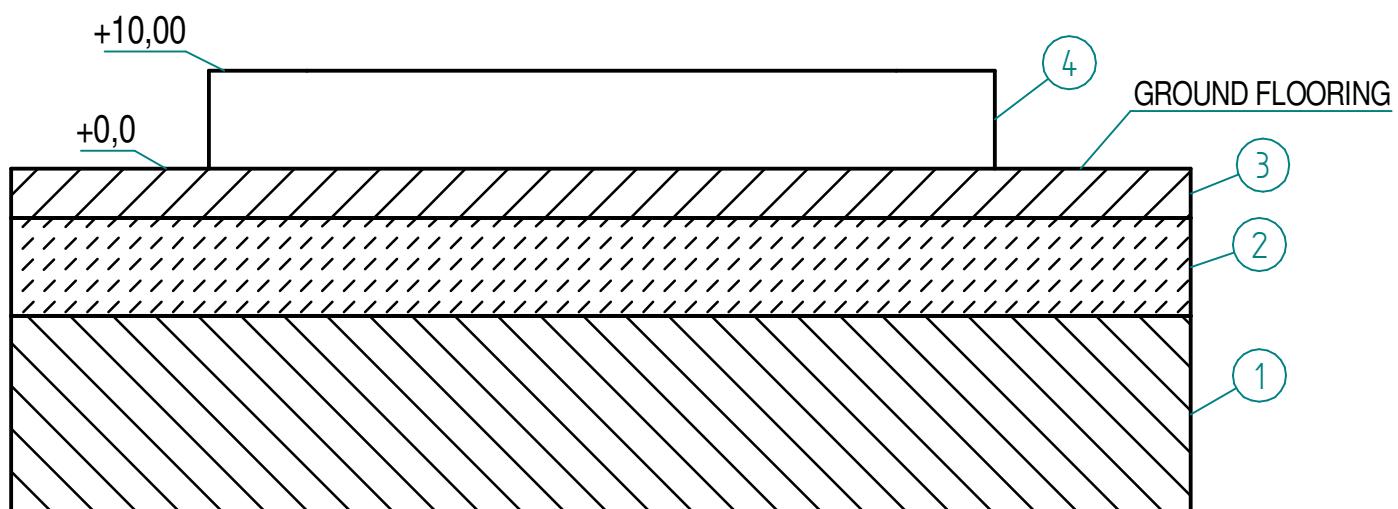

- 1) Washed sand
- 2) Lean concrete with 10 cm thickness with 5 mm diameter welded mesh
- 3) Walkable floor - Flooring as per your forecourt
- 4) cls r' ck 250 kg/cm²
- 5) Grounding obligation - Ground connection point of the structure (the cord must come out by 1 m from the flooring)
- 6) 50 mm diameter p.v.c. hose for passing the 3P+N+T type electric cable section 2,5 mm (the cable must come out at least 2 meters out of the flooring to allow the electrical connection)
- 7) Predisposition for eventual arrival of compressed air (from outside)
- 8) Predisposition for eventual centralized vacuum system for tokens
- 9) Free exit

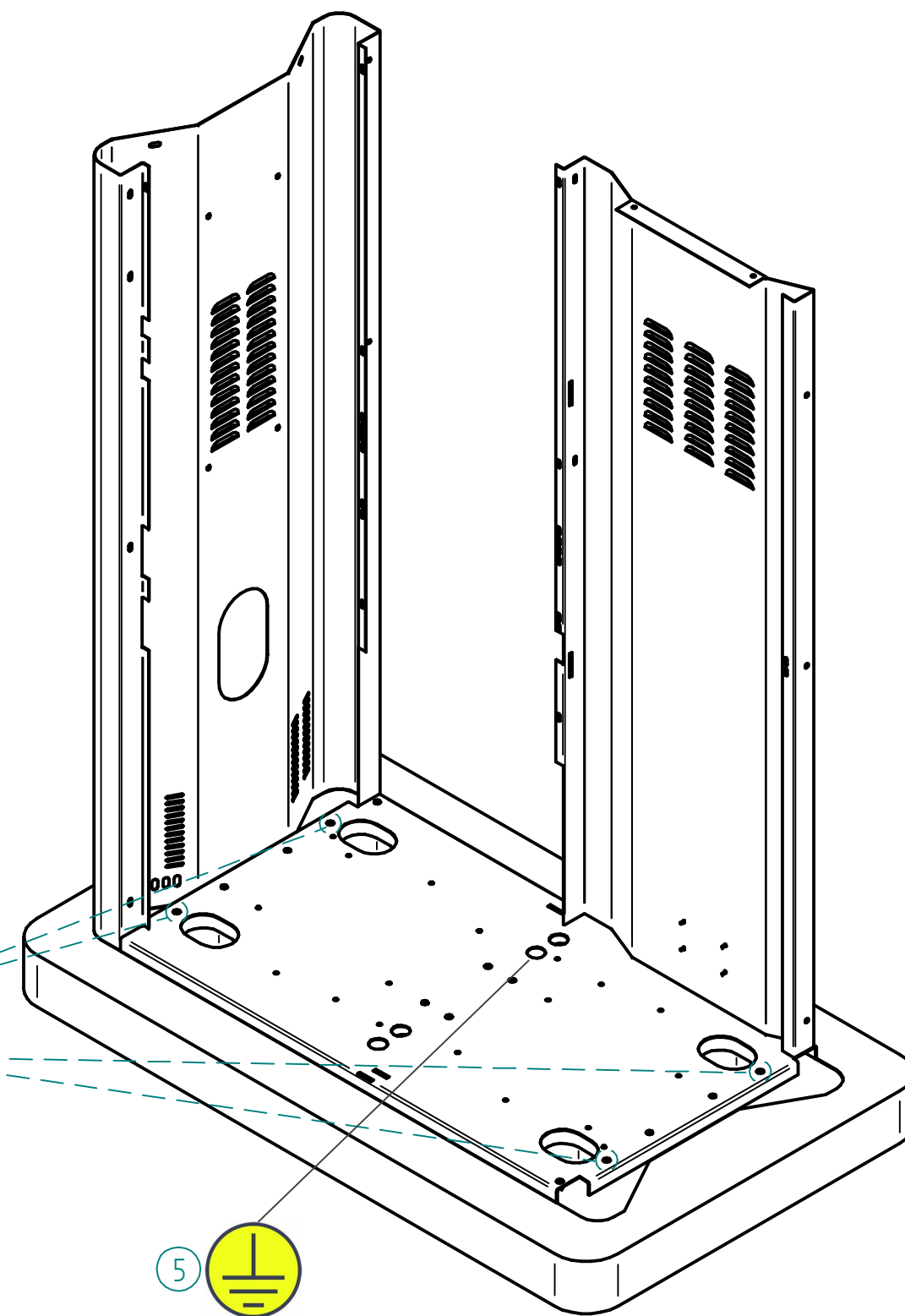



A.D. PRODUZIONE SRL

+39 02 33 50 24 97

info@adproduzione.it

www.adproduzione.com

VACUUM CLEANERS mod. AD-00DA and AD-01DA

Unite of measure: cm

CAUTION

- Interventions to be checked in accordance with geotechnical conditions of soil.
- Electrical connections made during installation must ensure the regulations in force.
- Installed power: AD-00DA = 2 x 2,2kW and AD-01DA = 2 x 3,0kW.
- Electrical cables must not be twisted, overlapping and rubbing against sharpe edge.
- All the extremities of the tubes must stick out by 20 cm.

EXAMPLE OF MASONRY WORKS

FOR TECHNICAL DETAILS ASK TO A PROFESSIONAL TECHNICIAN

- 1) Washed sand
- 2) Lean concrete with 10 cm thickness with 5 mm diameter welded mesh
- 3) Walkable floor - Flooring as per your forecourt
- 4) cls r' ck 250 kg/cm²
- 5) Grounding obligation - Ground connection point of the structure (the cord must come out by 1 m from the flooring)
- 6) 50 mm diameter p.v.c. hose for passing the 3P+N+T type electric cable section 2,5 mm (the cable must come out at least 2 meters out of the flooring to allow the electrical connection)
- 7) Predisposition for eventual arrival of compressed air (from outside)
- 8) Predisposition for eventual centralized vacuum system for tokens
- 9) Free exit

--- MACHINE MAIN DIMENSIONS

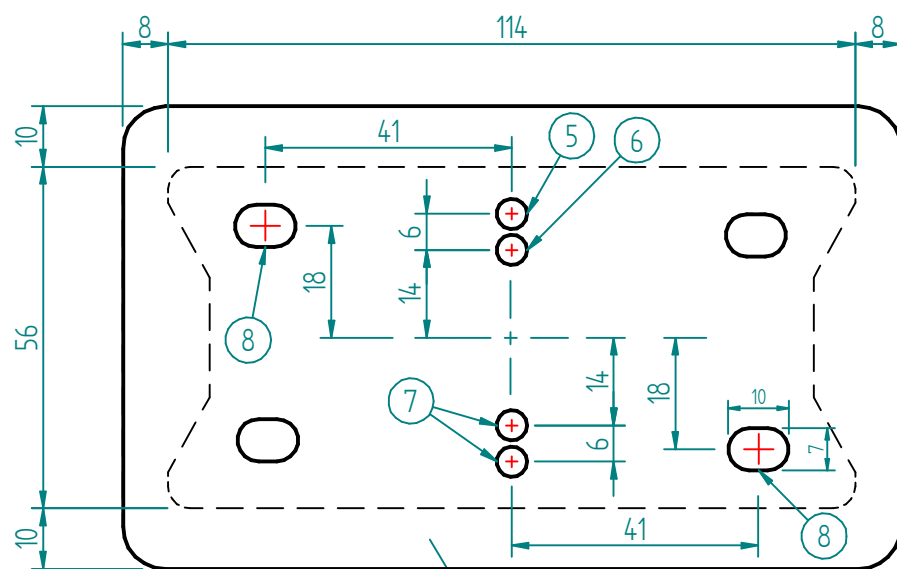

FRONT OF THE MACHINE

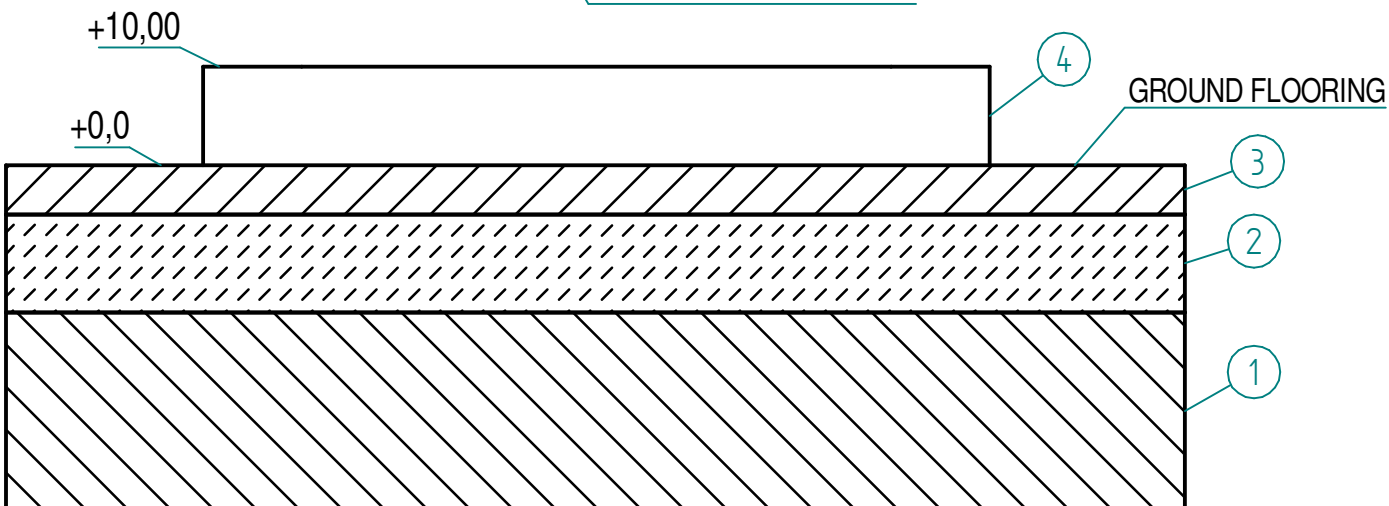

DETAIL B

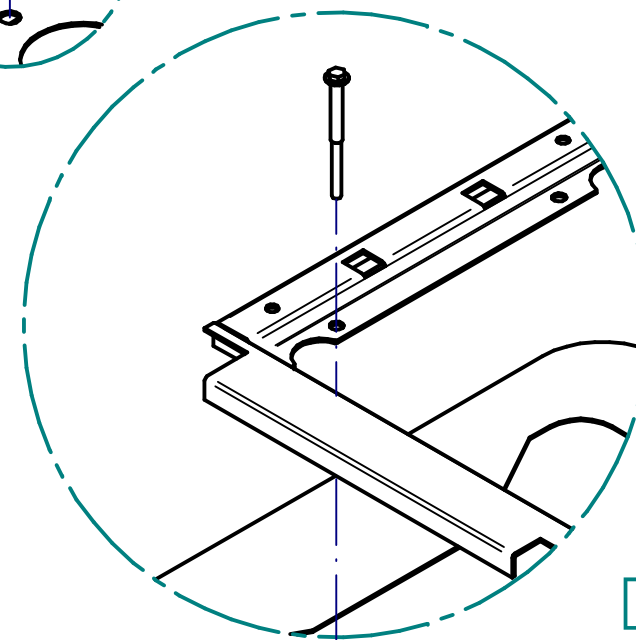
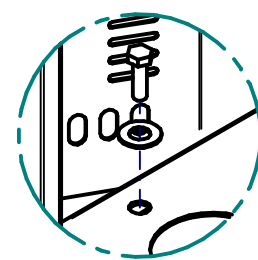

DETAIL A

